

FORMULA FORD 1600 KENT

2026
TECHNICAL
REGULATIONS



Technical Regulations for

Formula Ford

1600

Introduction

The first race for Formula Ford cars was held on July 2nd, 1967, using the 1498cc engine from the Cortina and ordinary road-going Firestone F100 tyres. Changes had to be made over the years to keep both the engine in line with current production, firstly to 1600cc and later to the cross-flow engine, whilst also improving the tyre specification.

None of these have changed the basic concept of the Formula.

No changes have been introduced to the current cars, except for the safety requirement of Lateral protection structures on 1996 and later cars only.

The current cross flow, 1600cc, "Kent" engine is no longer in production, and we are pleased that the formula is still thriving and wish it many more years of success.

The "Kent" engined formula now has its own regulations and they are no longer combined with the regulations for the 1800cc "Zetec" engined cars.

Copies of the regulations and other information can be obtained from the Web at:

www.fficom.com

or

The Motorsport UK Technical Commissioner
for Formula Ford:

Nigel Jones,
49, The Chase,
Eastcote,
Pinner,
Middlesex. HA5 1SH

Tel: 07802 276590

Email: njones6942@gmail.com

Ford Performance
Michael Norton
Ford Performance WRC Program Supervisor
Motorsports Regulations and Homologation
Tel: 01268 405978
Email: mnorton2@ford.com

Standard parts are available from Ford Dealerships, or Formula Ford International. All bespoke parts are available from Formula Ford International at:

FFI Components Ltd
18 Mill View
Hinckley
LE10 1XD
sales@fficom.com
Sara Bates
Mobile 07923 810132

Initial contact via email please, to ensure written record.

Warning

The following regulations have not been updated for several years. Irrespective of these regulations ALL cars must comply with at least the current minimum safety standards specified in the country of the competition. (Safety Helmets, Safety Belts, Fire Extinguishers etc.)

For Standard Ford Motor Company parts that are specified in these regulations, which customers find are no longer available through the Ford channels, should be reported to M Norton at Ford. The competitor must obtain the written consent from the Scrutineer responsible for that race meeting or championship prior to using the alternative part in competition.

Copyright

Ford Motor Company Ltd. retains the copyright for these regulations.

Technical Regulations

Formula Ford 1600

GENERAL

As with all regulations, "UNLESS IT SAYS YOU CAN DO IT. YOU CANNOT".

1 DESCRIPTION

Four-wheel, single seater racing car, as defined for Formula 3 (1985) and these regulations fitted with a Ford 1600cc GT "Kent" Engine.

2 SAFETY

These regulations are based on the current ASN National Competition Rules (NCR). All relevant and current ASN NCR apply.

3 CHASSIS

The chassis must be of tubular steel construction with no stress bearing panels except bulkhead and undertray, curvature of the undertray must not exceed 2.54cm. The undertray/floor (E 13.2.4) extends from the bulkhead forward of the pedals to the bulkhead between the fuel tank and the engine. Monocoque chassis construction is prohibited. Stress bearing panels are defined as, sheet metal affixed to the frame by welding or bonding or by rivets, bolts or screws which have centres closer than 15.25cm. Bodywork must not be used as stress bearing panels. The use of stabilised materials, composite materials using carbon and/or Kevlar reinforcement is prohibited.

3.2 Cars built after 1.1.87 and before 1.1.95 The internal cross section area of the cockpit from the driver's feet to behind his seat, shall nowhere be less than 700 cm² and a minimum width must be 25cm over the whole length of the cockpit. The only intrusion permitted into the cross-sectional area being the steering column.

3.3 Cars built after 1.1.95 The free internal cross section of the cockpit from the soles of the driver's feet to behind his seat shall at no point be less than 700cm². The only thing which may encroach on this area is the steering column. A free vertical section of minimum 25cm width maintained to a minimum height of 25cm with corners of maximum 5cm radius must be maintained over the whole length of the cockpit with the steering wheel removed. The driver normally seated in his driving position with the seat belts fastened and the steering wheel in place must be able to raise both legs together such that his knees reach the plane of the steering wheel in the rearward's direction: this action must not be obstructed by any part of the car.

3.4 Cars built after 1.1.87 The soles of the feet of the driver, seated in the normal driving position and with his feet on the pedals in the inoperative position, shall not be situated to the fore of the vertical plane passing through the centre line of the front wheels.

3.5 No engine oil or water tubes are permitted within the cockpit

3.6 Cars built after 1.1.95

The chassis must include an impact-absorbing structure fitted ahead of the front bulkhead of the tubular steel frame. This structure must be independent of the bodywork and must be solidly fixed to the extremities of the bulkhead (i.e. with bolts requiring tools for removal). It must constitute a box of 30cm minimum length, 15cm minimum height in any vertical section and 400cm² minimum total cross section. It must be metallic using honeycomb sandwich construction with a panel thickness of 15mm minimum. It is recommended, but not mandatory, that this safety feature is fitted to older cars.

3.7 Cars built after 1.1.96 must be built with a LATERAL PROTECTION STRUCTURE, defined as continuous panels whose projection on a vertical plane parallel to the longitudinal axis of the car shall be at least 15cm high, shall extend on either side of the car, at a minimum distance of 55cm from the car's longitudinal centre line between at least the transverse planes passing through the fuel tank rear face and the frontal extremity of the minimum cockpit opening, and at a minimum distance of 35cm from the car's longitudinal centre line between at least the transversal planes passing through the above extremity and the front rollover bar hoop. These panels shall be made from a composite material of 30cm² minimum cross section with a honeycomb core in metal giving adequate resistance to compression. The external skins shall be of aluminium alloy of a minimum thickness of 0.5mm or made up of another assembly of materials of equivalent efficiency. The panels must be securely attached to the bottom and at the upper extremity to the main structure of the car in such a manner as to ensure absorption of a lateral impact. The radiators may play the role of protective panels or of transversal struts. The periphery of the bodywork covering the Lateral Protection Structure, when viewed from below, must be curved upwards with a minimum radius of 5cm, and a maximum radius of 7cm with the exception of air entry and exit openings into the Lateral Protection Structure. The floor of the side pod must reflect the plan of the upper surface. The floor is to be in the same plane as the undertray in both directions, i.e. transverse and longitudinal, subject to all points

being within 2.54cm of any flat plane situated under the car (see Art 3.1).

4 BODYWORK

See table of single seater dimensions. (Appendix "B"). The use of composite materials using carbon and/or Kevlar reinforcement is prohibited. Bodywork is not required behind the vertical plane taken through the front of the topmost portion of the roll over structure. If bodywork is used it must conform with the following regulation.

- 4.1 Any device designed to augment aerodynamically the downthrust on the vehicle is prohibited, as are aerofoils, nose fins or spoilers of any type.
- 4.2 For cars built after 1.1.87 The engine cover must not extend rearwards past the rearmost point of the gearbox housing (no gearbox extensions permitted). The shape of the cover must not include any reflex curves and no flat surfaces are permitted within 15° of the horizontal
- 4.3 For cars built after 1.1.87 The lower rear bodywork (located below the wheel center line) is only permitted alongside and beneath the engine and can only extend from behind the cockpit to a line drawn through the rear axis. The incorporation of suspension or other fairings in this bodywork or separately is prohibited.
- 4.4 It is not permitted to construct any suspension member in the form of an aerofoil or to incorporate a spoiler in the construction of any suspension member
- 4.5 All cars must have at least two mirrors mounted so that the driver has visibility on both sides of the car (minimum surface area of each one: 55cm².)
- 4.6 For cars built after 1.1.95 Cockpit opening: The opening giving access to the cockpit must allow a designated horizontal template to be inserted vertically into the cockpit (not considering the steering wheel) down to 25mm lower than the lowest point of the cockpit opening. This template is defined by dimensions J,K,L in Appendix "B". The cockpit must be so conceived that the maximum time necessary for the driver to get out from his normal driving position does not exceed 7 seconds with all driving equipment being worn and starting with the safety belts fastened.
- 4.7 See also Lateral Protection Structures.
- 4.8 Only original factory specification parts can be used in front of the forward bulkhead. No additional material can be added

5 ENGINE

5.1 GENERAL

- a) Engines will be mounted upright and aligned fore and aft in the chassis.
- b) The addition of any material be it metal, plastic, or composite etc. by any means be it welding, bonding, encapsulation or encasement to any component is prohibited. However, specific repair of the mounting points of the cylinder block to the transmission or chassis are allowed, whilst other casting repairs may be allowed with prior written approval of the Technical Commissioner responsible for the Formula.
- c) Balancing of reciprocating and rotating parts is permitted only by removal of metal from locations so provided by the manufacturer.
- d) Pump, fan and generator drive pulleys and their retention bolts, washers and belts are free.
- e) Mechanical tachometer drives may be fitted.
- f) Generators are optional.
- g) The use of non-standard replacement fasteners, nuts, bolts, screws, studs and washers which are not connected with, or which do not support, any moving parts of the engine or its compulsorily retained accessories is permitted. Freedom granted to any fastener does not allow for freedom to move items relative to each other. For components that are granted the freedom for the fitment of a key or dowel, then material may be removed to allow the fitting of the key or dowel. Only one hole or keyway per component is allowed.
- h) The use of thread locking compounds is permitted.
- i) Gaskets are free except for the cylinder head, intake gaskets which must be standard Ford manufacture for the engine, and inlet manifold to cylinder head gasket which must be of approximate production thickness (see 5.3e).
- j) Any process of cleaning may be used on any component providing the surface finish, which must remain standard, is not affected.
- k) Forced induction is prohibited. Ram Air generated by the forward motion of the car is not considered as forced induction.
- l) The exterior surfaces only (of the complete engine assembly) of ferrous parts and the exterior surface of the aluminium Rocker Cover may be protected by paint or similar means. No internal component or surface may be coated by any protective finish. Other Ford produced aluminium components may be protected only on their external surfaces by a transparent clear varnish, or similar.
- m) Part numbers quoted were correct at the time the regulations were drafted. However, as with all companies, the Ford Motor Company Limited reserve the right to make changes to components for reliability or other reasons. Consequently, the part numbers quoted may be

superseded by later released parts. Full Ford part numbers do not necessarily appear on all parts.

5.2 PERMITTED ENGINE

The only permitted engine is the Ford 1600 GT "Kent" (also referred to as Mark II Escort 1600 "Sport") with a nominal bore 81 mm and stroke 77.6mm. Production tolerances (+ - 0.01mm) are permitted providing the total swept volume does not exceed 1604cc.

5.3 INDUCTION

a) The air cleaner may be removed or replaced, and a trumpet fitted.

b) Carburetor Type: Weber 32/36 DGV and DGAV (from 1600 GT "Kent" or 2000 SOHC NE engine).

Number on engine 1

Number of Main Venturi 2

Maximum dia. of Main Venturi 26.0/27.0mm

Maximum dia. of carb outlet to inlet manifold 32.0/36.0mm

c) It is permitted to change jets, open both throttles together, remove cold start devices and diffuser bar, fit internal and external anti-surge pipes, remove seals on emission control carburetors. No other modifications are permitted, chokes must remain standard and no polishing or reprofiling is permitted. Any means of reducing intake air temperature is prohibited. Any form of water injection is prohibited.

d) Inlet manifold: standard Ford production inlet manifold for 1600 GT "Kent" engine. The carburetor seat face may be machined to horizontal in the fore and aft plane. The water passage must remain intact but may be blanked off or plugged. The manifold may be machined externally to clear the throttle mechanism in the use of both throttles being opened together.

e) Carburetor to inlet manifold gasket Thickness 5.7mm ± 0.35mm Inlet manifold to cylinder head Thickness 0.86mm (max)

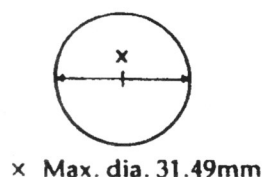
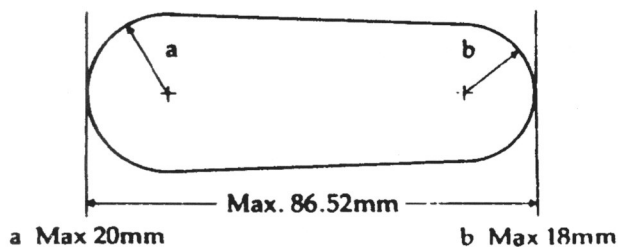

Manifold port diameter may be exceeded in vertical plane if casting is original and untouched

5.4 EXHAUST SYSTEM

a) The exhaust system and manifold are free, within Vehicle Regulations.

b) A mandatory silencer, Ford Part No. 9095317 (or old unit 9094277) must be fitted

5.5 CYLINDER BLOCK

a) It is permitted, as means of repair, to replace damaged cylinder bores with cast iron cylinder liners, all to standard dimensions.

b) Localised machining of the cylinder block is permitted to allow fitting of the dry sump system.

c) The crankcase breather may be altered or removed, but all breathers must discharge into a catch tank.

d) May be machined to maintain deck height.

5.6 CYLINDER HEAD (INCLUDING VALVES AND VALVE GEAR)

a) Non-standard rocker covers are permitted providing they in no way improve the performance of the engine. Water passages are not permitted in rocker covers.

b) Standard valve spring retainers must be used; only single valve springs are permitted. Shims are permitted, otherwise valve springs are free.

c) Push-rods, rockers, tappets, pedestals and shafts must remain standard except that recontouring of the valve stem contact pad on the rocker arm is permitted providing the maximum specified lift at the spring cap is not exceeded. The pedestals may be shimmed at the base to a maximum of 1mm. Rocker shaft springs are free.

d) Maximum permitted lift at the spring cap with zero tappet clearance:
inlet 9.042mm, exhaust 9.093mm.
Maximum permitted lift at the top of the push rod:
inlet 5.917mm, exhaust 5.943mm.

e) Valves must remain standard, if not original, replacement valves must have 'FFI' stamped on the stem, no reprofiling or polishing is permitted. The original 45° seat angle must be maintained. Distance apart at centres 39.12 ± 0.5mm. Maximum face diameter, inlet 39.62mm. exhaust 34.00mm.

Overall length inlet 110.92 ± 0.5mm.

Overall length exhaust 110.61 ± 0.5mm.

Valve stem seals are optional.

f) It is permissible to reshape inlet and exhaust ports by removal of metal within limits. Addition of material in any form is prohibited.

Maximum port diameter at manifold face: inlet 36.12mm, exhaust 29.41mm.

Inlet and exhaust port diameter may be exceeded if the original casting is visible and untouched at the gasket face.

g) It is permitted, as means of repair, to replace damaged valve guides and valve seats by replacement valve guides and valve seat inserts, all to standard dimensions

5.7 COMPRESSION RATIO

a) The maximum compression ratio will be controlled as follows:

i) Minimum combustion volume in piston 41cc (with piston at TDC in cylinder and no account taken of volume down from the crown to the top piston ring).

ii) Standard Ford cylinder head gasket Part No. 781M 6051 AA / 931M 6051 AA minimum compressed thickness 0.85mm, minimum diameter of cylinder head aperture 82.50mm.

iii) Pistons must not protrude above the cylinder block face at TDC. The cylinder block surface may be machined.

iv) Maximum permitted protrusion of the valves into the combustion chamber 1.2mm.

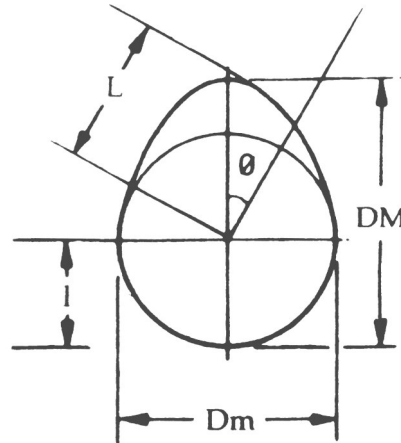

5.8 CAMSHAFT

a) The only permitted camshaft is that specified for Kent Formula Ford use. Part N° 771M-6250-BA conforming to the lift tables below.

b) The camshaft must remain entirely unmodified. It must be fully manufactured and ground to the Ford Motor Company profile by the designated supplier FFI also with the serial number in the example form 'FFI 103' on the rear face of the camshaft. It is prohibited to grind from blanks, regrind or reprofile. Tuftriding or Parkerising is permitted. Shot peening, shot blasting or polishing are prohibited. Offset dowels are permitted.

c) The cam profile is defined by determination of lift (L-l) against a flat-footed follower at various angles (θ). Maximum lift at all points on the camshaft must not be exceeded.

The standard Ford tolerances of ±0.1mm apply to the following camshaft table and drawing.

Dimension	Symmetrical	
	Inlet	Exhaust
DM (max)	33.60mm	33.65mm
Dm	27.78mm	28.15mm
Lift at 0°	5.87 mm	5.89mm
Lift at 5°	5.81mm	5.85mm
Lift at 10°	5.64mm	5.67mm
Lift at 15°	5.38mm	5.41mm
Lift at 20°	5.00mm	5.03mm
Lift at 30°	4.01mm	4.04mm
Lift at 40°	2.69mm	2.77mm
Lift at 60°	0.46mm	0.61mm
Lift at 90°	0.05mm	0.20mm

Angle between major axes of inlet and exhaust cams: 109°.

5.9 PISTONS

a) The only permitted piston is that specified for Kent Formula Ford use. Part number 711M-6102-DA/EA/CA supplied by FFI or pistons must be standard Ford production pistons for the 1600cc engine, unmodified in any way except for balancing and as detailed.

b) All three piston rings must be fitted, piston rings must be standard production or similar replacements, i.e. the compression rings must be one piece, with conventional plain gaps, chromium plating of the top ring is optional, the oil control rings must be either single piece, two piece, twin land type or apex three piece (two rails and an expander). Molybdenum faced top compression rings are permitted.

c) Pistons may be machined to achieve volumetric and weight balance and minimum weight. The piston bowl profile cannot be altered and must be as manufactured. Minimum weight complete with piston rings and gudgeon pin: 520gm, weight of gudgeon pin: 113 ± 2.0gm.

5.10 CONNECTING RODS

a) Connecting rods must be standard Ford Part No. 2737E 6200 B. Machining is permitted to remove metal from the balancing bosses on the big-end cap and at the little end to achieve balance only. Polishing is prohibited. Big-end cap bolts are free, whilst respecting the minimum weight.

Minimum weight (including bolts and small end bearing) 630gm.

5.11 CRANKSHAFT

a) A standard crankshaft with part number 711M-6303-AE or steel crankshaft with part number 711M-6303-AG also with the 'FFI' stamp and serial number in the example form 'FFI 101' along with the logo on the first journal must be used. Machining to achieve balance and fit is permitted. Tuftriding, shot peening and shot blasting are permitted. Polishing is prohibited. Crankshaft minimum weight: 11.2kg.

b) Crankshaft pulley is free as is tooth belt drive.

- c) It is not permitted to alter the number of bearings or fit bearings of less than standard production width.
- d) Standard oversize and undersize bearings are permitted.
- e) The rear main journal may be fillet rolled in the radius

5.12 FLYWHEEL AND CLUTCH

- a) The flywheel and clutch assembly must be standard components. To achieve minimum weight and balance, material may be removed from the originally machined surfaces, rim/flange etc. For rectification, the clutch mating face may be resurfaced. Cast surfaces must remain in original condition. It is permitted to use a similar pattern replacement clutch (i.e. conventional single diaphragm spring) driven plate with shock absorber springs. Organic friction material only is permitted. Racing clutches are prohibited.
- b) Flywheel bolts are free and locating dowels are permitted.
- c) It is permitted to secure the starter ring to the flywheel.
- d) Flywheel minimum permitted weight is 8.2kg

5.13 LUBRICATION SYSTEMS

The lubrication system, external to the engine, is free. Existing standard production oilways, linings or oil grooves may be enlarged or reduced, but no additional ones are permitted. Standard friction surfaces must remain unchanged. Dry sump is permitted, oil coolers are free.

5.14 COOLING SYSTEM

- a) A liquid cooling system is mandatory, but the radiator is free. Only the standard water pump is permitted.
- b) The radiator, if housed in or incorporating a cool air scoop or deflector, must comply with bodywork regulations.

5.15 FUEL PUMP

- a) The engine mounted mechanical fuel pump may be replaced by an electrically operated type with a delivery pressure of 0.2 - 0.3 bar (3.0 - 4.5psi) and a nominal flow rate of 115L/h. The pump must be ethanol tolerant and be controlled by a switch accessible by the driver whilst strapped into the cockpit.
- b) Fuel lines must be ethanol proof and all fittings made of ethanol resistant material (i.e nylon or brass, NOT aluminium or steel).
- c) Fuel cooling radiators are permitted, within safety regulations, but must be mounted within the main chassis frame.
- d). If an electrical pump is installed, the mechanical pump may be left on the engine or may be removed and replaced with a suitable oil-proof blanking plate.

- e). If using an electric pump, it is strongly recommended that a pre-filter is installed on the inlet to the pump in addition to a filter on the outlet. Any filter(s) used must not contain any glass components.
- f) The fuel pump must be controlled by a suitably current rated switch: either a separate single switch or via one pole of a double pole ignition switch, in either case the 12v supply to the pump switch must be fed from the switched side of the battery master cut out switch.

5.16 DISTRIBUTOR

- a) Distributors are free providing they retain the original drive and location.
- b) The distributor is defined as the component which triggers the LT current and distributes the HT ignition current. The ignition timing may only be varied by vacuum and/or mechanical means. It is prohibited to use any other method or component to trigger, distribute or time the ignition.
- c) It is permitted to mount a simple indicating pointer to the engine to facilitate the timing of the distributor with respect to the crankshaft/flywheel.

6. SUSPENSION

- a) The following parts must be of alloy steel or other ferrous material: wishbones, rockers, push and/or pull rods. All other stress bearing components must be metallic with no composite materials allowed. It is permitted to incorporate suspension mounting points on the engine and transmission assembly.
- b) Active suspensions are prohibited, as is any system which allows control of the flexibility of the suspension springs, shock absorption and trim height when the car is moving.
- c) Anti-roll bars for front and/or rear suspension may be capable of manual adjustment by the driver when seated in the car.
- d) Simple ovalised tubes which have the same section top and bottom are not considered to be an aero foil.
- e) Cars fitted with suspension anti intrusion bars must have any slip joints in their construction effectively locked This link must be circular with a minimum diameter of 10 mm, and any slip joint must be bolted or pinned and located in the centre of the span.

7 BRAKES

Only brake discs made predominantly from Ferrous material are permitted. Calipers must be of Ferrous material with a maximum of two working cylinders per caliper. Brake pad materials, including carbon metallic, are free.

Hand operated brakes:

For the sole purpose of assisting the driver during gradient starts, a simple cable operated brake

assist system may be used. This may not in any way affect the performance of the main braking system and may not be connected to the hydraulic circuits. It must be solely mechanical.

8 SHOCK ABSORBERS

Light alloy casings and/or Separate reservoirs for fluid/gas are prohibited, otherwise free. Any form of active damping is prohibited. Any method of altering the damper performance by the driver whilst seated in the car is prohibited. The shock absorber casing is defined as the item which contains the piston, fluid/gas, and moving parts which control the damping action.

9 STEERING

The steering must consist of a mechanical link between the driver and the wheels, rear wheel steering prohibited, otherwise free.

10 WHEELS & TYRES

a) 13-inch diameter steel wheels with a maximum rim width of 5.5 inch are the only wheels permitted. They must be of commercial manufacture, but the offset may be altered. (It is recommended that weekly checks for cracks be carried out and that the wheels be replaced twice a year).

b) The only tyres permitted are those listed in the Sporting Regulations for the event. Minimum tread depth 1mm at the start of each practice session and race.

c) Tyre warmers are not permitted. Tyre covers whose only function is to protect the tyre in the paddock area are allowed. Tyre warmers found at the circuit will be judged to be available for use.

11 TRANSMISSION

a) The gearbox must contain not more than four forward gears and include an operable reverse gear, capable of being engaged by the driver whilst normally seated. The ratios are free.

b) Rear wheel drive only is permitted.

c) Final drive ratio is free.

d) Torque biasing, limited slip and locked differentials are prohibited. Non-ferrous differential components prohibited.

e) Gear change must be manual in operation.

The gearchange must use the conventional 'H' pattern gearchange gate. Any gear change mechanism that only allows sequential selection of gears is not permitted.

f) The only position for the main gear cluster will be wholly behind the rear axle output shaft centre line, and in line with the crankshaft centre line. Transverse, vertical, or other non-in-line configuration will not be allowed.

12 FUEL SYSTEM

a) Tanks outside the chassis frame must comply with FIA Spec FT3.

b) Inboard tanks, covered externally with a fireproof coating, are acceptable for events of less than 70km.

c) Protection must at all times comply with NCR Ch.7 App.2 Art.6.1 and NCR Ch.7 App.2 Art.6.5 (Bulkheads). A metal tank coated with GRP does not comply.

d) Maximum capacity 41 litres unless carried in FIA spec FT3 tank or better.

e) Use Permitted Fuel (see definition Nomenclature and Definitions) except, subject to prior written authority having been given by the ASN, where permitted otherwise under event SRs, and Championship Regulations. Where Authority for FIA specification fuel is given by the ASN the fuel must be in compliance with FIA Appendix J Article 252, Article 9.

f) At the end of practice and the race at least 3 litres of fuel from the tank of the competing car must be available to the scrutineers for analysis. Compliance with minimum weight for the car will be taken before the fuel is removed.

13 STARTING

a) Compulsory electric starter with electrical source of energy carried on board the car, and able to be controlled by the driver when normally in his seat.

b) A supplementary external source of energy temporarily connected to the car may be used to start the engine whilst in the pit area.

14 WEIGHT

Minimum car weight at any time during the competition is 420Kg,

The minimum weight of car plus driver, at any time during competition shall be 500kg

15 ENGINE SEALING

All engines should have provision for scrutineer's wire seals. 1/16-inch dia. holes pre-drilled in readily accessible locations on installed engines must be available. Failure to comply renders the entrant liable to a fine.

a) Sump - two holes through the cylinder block/ sump joint flange, one either side of the engine.

b) Timing Cover - at least two retaining screw heads must be cross drilled.

c) Rocker Cover - at least two retaining screw heads must be cross drilled.

d) Inlet Manifold - at least two retaining bolt heads to the cylinder head must be cross drilled.

e) Carburetor - at least two retaining nuts to the cylinder head must be cross drilled.

f) Bellhousing - at least two retaining bolts to the engine must be cross drilled to enable clutch and flywheel to be adequately sealed, OR competitors must be prepared to remove either engine or transmission to enable sealing of clutch and flywheel in which case at least two clutch

cover retaining bolts must be cross drilled. Failure to comply renders the engine ineligible.

16 RED WARNING LIGHT

Red Warning Light: A rearward facing red warning light of 21 watts, with surface area minimum 20cm², maximum 40cm², or of 21 watts with a surface area minimum of 50cm² and with lens and reflector to EU Standards, must be located within 100mm of the vertical centre line of the vehicle and be clearly visible from either side. When viewed from the rear the light must not be obstructed by any part of the vehicle. An alternative light unit of equal or enhanced constant luminosity or LED lights that are either homologated by the FIA or comply with relevant EU Regulations may be used.

The rear warning light must be energised when visibility is poor.

17 SEAT

The vehicle occupant(s), seated in their normal position, wearing normal equipment, with seat belts fastened and the steering wheel in place, must be able to evacuate the cockpit in a maximum of 10 seconds.

18 MISCELLANEOUS

a) The use of titanium, ceramic, high strength composites and similar materials is prohibited.

b) Electronic dashboards and Data logging equipment are allowed subject to them having no influence whatsoever on the behaviour of the car during competition. All information obtained from any Data logging or storage equipment shall be made freely available to the Scrutineer on request.

c) Competitors are reminded that only modifications or additions specifically covered by these regulations are permitted. Engine components not covered by these regulations must remain completely standard and unmodified. In cases of dispute on engines, reference will be made to Ford Motor Company Limited drawings.

d) Vehicles defined in these regulations are required to comply with the section of the the ASN NCR covering General Vehicle and Race Vehicle which apply to single seater racing cars.

e) The use of carbon and/or Kevlar reinforcement is prohibited. (Unless expressly permitted). Items such as Carbon Fibre Dashboards (nonstructural) and Mirrors are permitted

19 Frontal Head Restraint

An FIA approved FHR device, fitted in accordance with FIA regulations, is:

(i) Mandatory for the driver of a Single Seater Racing Car with the exception of period defined cars (pre-1977)

PRE-1974 FORMULA FORD 1600

1 DESCRIPTION

Single seater racing cars complying with current Formula Ford 1600 regulations, and these regulations, manufactured prior to 1st January 1974.

2 CHASSIS

The chassis specification must remain fundamentally unaltered from original manufacture. Wheelbase, Track, and pick-up points must remain to manufacturers specification.

3 PERMITTED MODIFICATIONS

To current Formula Ford-1600 regulations.

3.1 Any modification of which the primary purpose is safety or driver comfort.

3.2 Bodywork is free within FF-1600 dimensions.

3.3 Coil springs, shock absorbers, anti-roll bars and steering rack are free providing they fit to the same original locations.

3.4 Wheel off-sets may be varied to alter track dimensions by a maximum of 3 inch.

3.5 All transmissions in production before 1st January 1974 in FF are permitted.

3.6 Make and type of drive shaft is free.

3.7 The number, type and location of radiators is free.

4 Miscellaneous

4.1 Cars may be updated to the specification of the latest model built by the manufacturer which appears in the list of eligible vehicles (e.g. Merlyn Mk1 1A up to Mk24 specification).

4.2 ELIGIBLE CARS if built prior to 1st. January 1974

**Pre 31/12/71 (source *P A Motorsport*)

Alexis 14,15,18,18B**

Alexis 14B to 24B

Beach MkII**

Bee Gee (71)**

Beattie (70)**

Blackjack (68)**

Bobsy (69)**

Bowin P4/P4A**

Centaur - Scholar (69-70)**

Caldwell D9, D9B**

Cooper Chinook (70)**

Cougar

Crossle 16F, 25F & 20F**

DRW Mk8**

Dulon LD4, LD4A to LD4C, LD9,**

Dulon MP15 & MP15B

Eldon PH6, PH8, Mk10 to 1 0C**

Eldon Mk10 to 10C

Elfin 600 (69-72)**

Forsgrini Mk 12**

Ginetta G18, G18B**

Hamlen FF69**

Hawke DL2, DL2A, DL2B,**
 Hawke DL9, DL10, DL11
 Huron FF (71)**
 Image FF1
 Jamun T2, T3**
 Jomic Mk2A
 Jomo (67-71)**
 Ladybird Mk8, Mk9**
 Legrand Mk10**
 Lenham P80FF**
 Lola Mk5A T200, T202, T204** 340
 Lotus 31 51, 51B. 51C 61, 61M, 61R, 61MX,
 69**
 Macon MR6, MR7, MR7B, MR8, MR8B**
 March 709, 719**
 Mallock,U2 Mk9, U2Mk9B, U2 Mk9DD**
 U2Mk11B
 Martini 69-71**
 Matek
 McNamara FFA**
 Merlyn Mk9, Mk11A, Mk17, Mk17A, Mk20,
 Mk20A**
 Merlyn Mk24 Mk25
 Micron**
 Mirage M5**
 Mistrale (69-70)**
 Mystere (67), Mystere Mk2**
 MRE FF72, FF73
 Nike Mk4, Mk6, MK10**
 Nike Mk10B (prior to 1.1.74)
 Nomad KH/FF16
 Norvic
 Oscar
 Palliser WDF1, WDF2, WDF3**
 Piper (67)**
 Pirola (71)**
 Pringett-Mistrale (69-70)**
 Raven (70)**
 Ray 71**
 Ray 72,73

Rostron CT1, CT2, CT3, CT4**
 Royale RP2, RP3, RP3A**
 Royale RP16, RP16A
 Tecno FF (70)**
 Titan Mk4, Mk5, Mk6, Mk6A**
 Titan Mk6B, Mk6C
 Van Dieman RF73
 Viroy (69-70)**
 Winkleman WDF1, WDF2, WDF3,**

Specials

Brabham BT21 /28**
 Chevron B1 5/17**
 Kvantti Mk1
 March 718/2**
 Smith Ford Special**
 Varo (68) (Lotus 22 derivative)**

APPENDIX "B"

~ Table of Single Seater dimensions

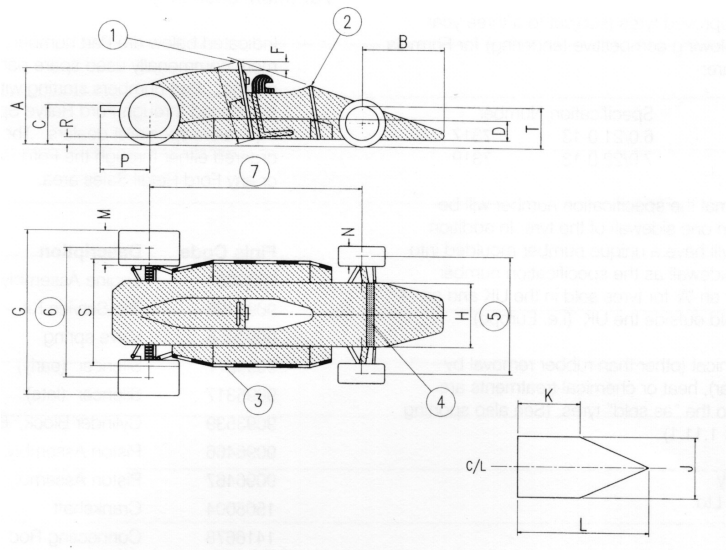

- | | |
|---------------------------------|----------------------------------|
| 1. Safety roll over bar | 2. Substantial support structure |
| 3. Lateral Protection structure | 4. Substantial structure |
| 5. Front track | 6. Rear track |
| 7. Wheelbase. | |

Notes

Maximum height is measured with the driver aboard.

Maximum height excludes safety roll-over bar on which there is no maximum height

Single seater dimensions - refer to drawing

(A) Maximum body height measured from ground	90
(B) Maximum front overhang from front wheel axis	100
(C) Exhaust height measured from the ground	60 Max
(D) Minimum height of Lateral Protection Structure	15
(E) Minimum safety roll-over bar length in line with drivers spine	92
(F) Minimum allowed helmet clearance	5
(G) Maximum width	185
(H) Maximum body width behind front wheels	95
(J) Minimum cockpit opening	45
(K) Minimum cockpit parallel opening length	30
(L) Minimum cockpit overall opening length	60
(M) Maximum rear wheel width	5.5 inch
(N) Maximum front wheel width	5.5 inch
(P) Maximum exhaust length from rear wheel axis	60
(R) Minimum ground clearance	4
(S) Maximum width including lateral protection structure	130
(T) The maximum height of any part wider than 110cm ahead of the front wheels is not to exceed the front rim height	
Minimum wheelbase	200
Minimum track	120
Wheel diameters	13 inch

ALL dimensions in cm unless specifically stated

APPENDIX "C"

The only approved for Formula Ford cars are:

ACB10

TYRES

Front Tyre - 6.0/21.0-13 – Specification Number 8317
Rear Tyre – 7.0/22.0-13 – Specification Number 8319

ACB9

Front Tyre - 5.0/22.0-13 – Specification Number 17680
Rear Tyre – 6.5/23.0-13 – Specification Number 17681

The specification number will be moulded on one sidewall of the tyre. Every tyre will have a unique barcode and corresponding number moulded into one sidewall.

No mechanical (other than rubber removal by normal wear), heat or chemical treatments are permitted to the "as sold" tyres.

Supplied by
Nova Motorsport Limited
Cory Way
West Wilts Trading Estate
WESTBURY
Wiltshire
BA1 4QT

Phone: TBC
Email: info@novamotorsport.com

UK Supply through HP Tyres Ltd.
HP Tyres Ltd
Units 5 & 6, Broad March Trade Park,
Long March Ind Est
Daventry, Northants
NN11 4HE

Tel: +44 (0) 1327 301887
Email: office@hptyres.com

See **sporting regulations** for the make, type and number of tyres that can be used at any race meeting.

FORMULA FORD PARTS LISTING**MANDATORY PARTS**

CRANKSHAFT (ARROW RACING)	9000000	771M-6303-AE
CRANKSHAFT (SCAT) RECOMMENDED RED LINE 6,800RPM	9094898	711M-6303-AG
CAMSHAFT	91572456	771M-6250-BA
PISTON ASSY WITH RINGS - MAHLE	9096466	711M-6102-CA
PISTON ASSY WITH RINGS - FEDERAL MOGUL (WITH CENTRE BOWL)	NLA	711M-6102-DA
PISTON ASSY WITH RINGS - FEDERAL MOGUL (WITH OFF SET BOWL)	NLA	711M-6102-EA
VALVES INLET	91596693	801M-6507-EA
VALVES EXHAUST	96077327	791M-6505-DA
GASKET CYLINDER HEAD, OEM or FFI Logo	95028795	931M-6051-AA
GASKET INLET MANIFOLD	95028798	931M-9441-AA
SILENCER OE or with FFI ID	9095317	9095317

PARTS AVAILABLE FROM SKY FORD / FFI

DESCRIPTION	FINIS	PART NUMBER
CYLINDER BLOCK BRAND NEW`	9093540	710M-6010-BA**
CYLINDER BLOCK RECONDITIONED WITH NEW LINERS NLA	NLA	H711F-6010-BA
CYLINDER HEAD	POA	711F-6085-CA
CRANKSHAFT (STD)	NLA	771M-6303-AE
CRANKSHAFT (STEEL – SCAT) RECOMMENDED RED LINE 6,800RPM	9094898	711M-6303-AG
CAMSHAFT	91572456	771M-6250-BA
PISTON ASSY WITH RINGS - MAHLE	9096466	711M-6102-CA
PISTON ASSY WITH RINGS - FEDERAL MOGUL (WITH CENTRE BOWL)	NLA	711M-6102-DA
PISTON ASSY WITH RINGS - FEDERAL MOGUL (WITH OFF SET BOWL)	NLA	711M-6102-EA
CIR CLIP (PISTON)	NLA	E860082 S
PISTON RING KIT	NLA	751M-6149-AA
CONROD *** P/No 2177EB acceptable as originally from AX Block NLA	9094722	2737E-6200-B***
CONROD PATTERN PART		FFI9094722
MANIFOLD INLET	NLA	V821F-9425-AA 711F-9425-HC
CARBURETTOR NLA	NLA	751M-9510-AA
CARB FLOAT PLASTIC NLA	NLA	71HF-9555-BA
VALVES INLET	91596693	801M-6507-EA
VALVES EXHAUST	96077327	791M-6505-DA
VALVE SPRING (HEAVY)	96020950	731M-6513-AA
VALVE SPRING RETAINER	96005893	721M-6A536-AA

COLLETS	91420824	2733E-6518-A1
ROCKER SHAFT	91433716	2733E-6563-A
ROCKER SHAFT COMPLETE	NLA	2733E-6563-B
ROCKER ARM RH NLA	NLA	2733E-6529-A
ROCKER ARM LH NLA	NLA	2733E-66530-A
ROCKER SHAFT SUPPORT	91710822	105E-6531-B
ROCKER ADJ.SCREW	91433715	2733E-6549-A
SCREW ROCKER COVER	91758441	50527-S8
CAMSHAFT SPROCKET	POA	105E-6256-B
PLATE SPROCKET RETAINER	91710511	105E-6258
THRUST PLATE (CAMSHAFT)	91710523	105E-6269
PLATE RETAINER (CAMSHAFT)	91744817	105E-6255
TIMING CHAIN	96156318	86BM-6268-A2A
TIMING CHAIN / ENDLESS NO LINK / NON FORD	NLA	86BM-6268-A2B
TENSIONER	NLA	77BM-6K254-AA
TENSIONER PAD	NLA	E62C-P-7
TENSIONER KIT (COMPLETE WITH TENSIONER PAD)	91708153	E320-Z-1
TAPPETS NLA	91662936	89BM-6500-AB
PUSH RODS NLA	NLA	2737E-6565-A
CRANKSHAFT SPROCKET NLA	NLA	2730E-6306-A
CRANK WOODRUFF KEY	91760157	115004-ES
LOCKWASHER – SUMP	91628314	E832108-571M
TIMING COVER	NLA	77BM-6059-AE
REAR COVER	96024782	731M-6K301-AA
CLUTCH COVER	91420697	75AB-7563-BA
CLUTCH DISC (STD)	91428629	2735E-7550-C
CLUTCH DISC (HD)	2257100	2735E-7550-D
SPIGOT BRG	91596468	82ET-7600-DA
FLYWHEEL (NO GEAR) NLA	9094947	751M-6375
FLYWHEEL + INERTIA RING GEAR NLA	9094949	751M-6375-DA
RING GEAR INT 110T (10.048)	91483403	701M-6384-AA
RING GEAR INT (110T) (10.167)	91483404	701M-6384-BA
INERTIA FLYWHEEL	9094949	MS15FF-6375-AA
PRE ENGAGED FLYWHEEL	9094951	MS15FF-6375-BB
RING GEAR PRE EN 135T (10.167)	91451391	70HM-6381-BA
FUEL PUMP	96132168	83BF-9350-AA
FUEL PUMP / NON FORD ALTERNATIVE NLA	96132169	83BF-9350-BA
WATER PUMP	91518093	W88FX-8591-CA
OIL PUMP GEAR	91710827	105E-6551
OIL PUMP GEAR PIN	93415834	72432-S

CAM BEARING KIT (AE)	9196261	77BM-6260-AA
BEARING CAM FRONT (FORD)	6176756	89BM-6261-CA
BEARING CAM CENTRE (FORD)	1564428	77BM-6262-EB
BEARING CAM REAR (FORD)	1564428	77BM-6262-EB
CRANK MAIN BEARING (STD) (AE)	96014924	731M-6333-CAA
BIG END BRG (STD)	96014911	731M-6211-A1A
SMALL END BRG KIT.	91744694	105E-6207-B
CRANK THRUST WASHER	91078671	98FF-6308-AB
CRANK THRUST WASHER (HD) (AE)	1561800	731M-6308-DA
CYL HEAD BOLTS LONG 3.79	91455640	681F-6065-AA
CYL HEAD BOLTS SHORT 2.51	91455641	681F-6065-BA
FLYWHEEL BOLTS	91427779	120669-ES
CLUTCH COVER BOLTS	91568872	304634 S80
BIG END BOLTS (STD)	91641896	2733E-6215-B
BIG END BOLTS (HD)	91641897	2733E-6215-C
BIG END BOLTS (HD – ARP)	91641898	2733E-6215-D
CAMSHAFT DOWEL	91744815	E93A-6253
CONROD DOWEL	91555368	116336-ES100
FLYWHEEL DOWEL	91665133	W70043-S300
GEARBOX DOWEL	91302132	W701350-S437
PLUG OIL GALLERY SMALL	91521644	E650411-572
PLUG OIL GALLERY LARGE	91759055	87837-ES2
CORE PLUG HEAD	96110418	353000-S71
CORE PLUG BLOCK / REAR - STD 051mm	91628322	119778-S71
CORE PLUG BLOCK / REAR - O/S 0.52mm	96148261	E857116-S71
CORE PLUG BLOCK / SIDE - STD 041.6mm	96110418	353000-S71
CORE PLUG BLOCK / SIDE - O/S 042.6mm	91000478	353000-S71
DISTRIBUTOR - ELECTRONIC NLA	NLA	R86BF-12100-BA
DISTRIBUTOR - CONTACT NLA	NLA	R77BF-12100-FB
DISTRIBUTION CAP NLA	90710254	117-10254
ROTOR ARM NLA	NLA	82HF-1200-AA
POINTS NLA	NLA	83SF-12107-AA
CONDENSER NLA	NLA	78BF-12300-AA
DISTRIBUTOR CAP NLA	NLA	920X-12276-ALA
ROTOR ARM NLA	NLA	920X-12200-AA
POINTS NLA	NLA	902X-12107-AA
CONDENSER NLA	NLA	920X-12300-AA
DISTRIBUTOR GEAR	NLA	C3AH-12390-B
IGNITION COIL NLA	NLA	79BB-12024-AA
LEAD (ELECTRONIC) NLA	NLA	84AG-12045-BA
PLUG LEAD SEPARATOR - RUBBER	91608178	82HF-12297-AA

PLUG LEAD SEPARATOR – PLASTIC NLA	NLA	E864816-S
SILENCER	9095317	9095317
GASKETS		
GASKET KIT DE COKE	91602013	D691-6014-AA
GASKET CARB BASE	91665187	76XF-9447-AA
GASKET CARB TOP COVER	91493692	71HF-9519-AA
GASKET CYLINDER HEAD	95028795	931M-6051-AA
GASKET ROCKER COVER	91421437	2733E-6584
SEAL VALVE STEM NLA	96008688	731M-6571-A1A
SEAL VALVE STEM (SPRING) NLA	91474550	70HM-6571-A1B
GASKET INLET MANIFOLD	95028798	931M-9441-AA
GASKET EXHAUST MANIFOLD	5028799	931M-9448-AA
GASKET EXHAUST MANIFOLD	5028800	931M-9448-AB
GASKET THERMOSTAT	91628164	84BF-8255-AA
GASKET FUEL PUMP	95028797	105E-9374
SEAL DISTRIBUTOR	91751884	204E-12143
SEAL CRANK FRONT	91031223	83BM-6700-A3A
GASKET TIMING COVER	91536187	681M-6020-AB
SEAL CRANK REAR	91641893	83HM-9701-A1A
GASKET REAR COVER	95028796	931M-6344-A
GASKET OIL PUMP	91710882	105E-6659
SEAL SUMP FRONT NLA	91454237	681F-6722-AA
SEAL SUMP REAR NLA	91454238	681F-6723-AA
SUMP GASKET LH NLA	91487262	681M-6711-AA
SUMP GASKET RH NLA	91487265	681M-6710-AA
GASKET DRAIN PLUG	1454118	70TM-6734-AA

**Additional acceptable Block Numbers

711M-6010-16K

711M-6015BA

831C6015B34/R34(service block South African casting)

Casting Code "AX"

NLA

NLA stands for No Longer Available through the Ford Network. Any item annotated with NLA may be sourced as a pattern part, no Ford Logo. It should however be noted that any such part must comply with the regulations in full, where stated. This means, material, weight and size, all of which can and may be checked against an original reference part. Original part numbers remain for reference

POA

POA stands for price on application. This means that there may well be an opportunity to source an original part, that is no longer available from the Ford network, But, the part may be re-conditioned, and prices for these parts will differ, depending on availability and re-conditioning costs.